

PROPUNERE APARTAMENTARE -PARTER
 Scara 1:100 Anexa Nr. 1.37 la regulament

Nr. Cadastral al terenului	Suprafata (mp)	Adresa imobilului:
	342.5	Str.Leordeni, Nr. 11, LOT 1 (Cv. 32, P. 807) Oras Popesti Leordeni, Jud.Ilfov
Cartea Funciara colectiva nr.	UAT	Oras Popesti Leordeni, Jud.Ilfov
Cod unitate individuala (U)	CF individuala	

Elena Onos

Semnat digital
 de Elena Onose
 Data:
 2020.08.28
 11:10:56
 +03'00'

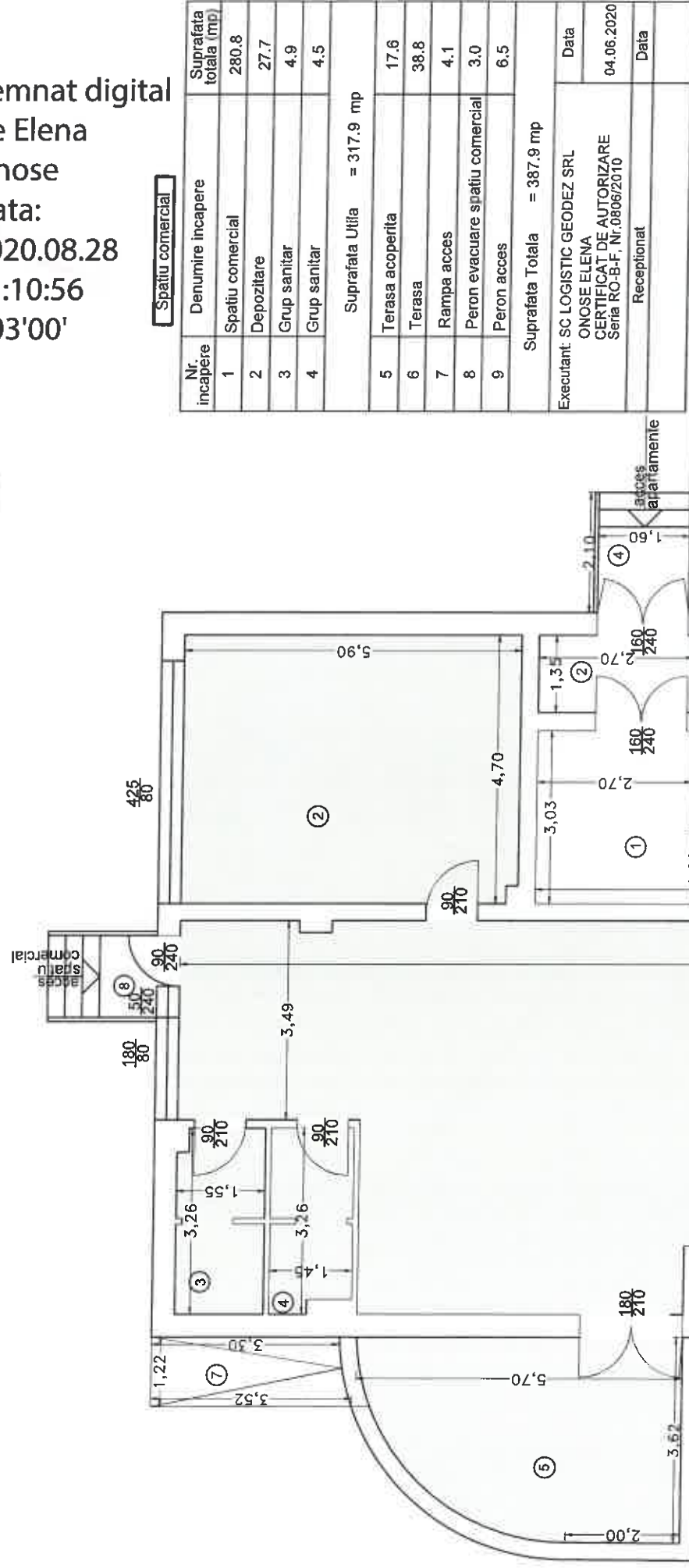

Spatiu comercial		Suprafata totala (mp)
Nr. incaperi	Denumire incaperi	
1	Spatiu comercial	280.8
2	Depozitare	27.7
3	Grup sanitar	4.9
4	Grup sanitar	4.5
Suprafata Utila = 317.9 mp		
5	Terasa acoperita	17.6
6	Terasa	38.8
7	Rampa acces	4.1
8	Peron evacuare spatiu comercial	3.0
9	Peron acces	6.5
Suprafata Totala = 387.9 mp		
Executant: SC LOGISTIC GEODEZ SRL		Data
ONOSE ELENA		04.06.2020
CERTIFICAT DE AUTORIZARE		
Seria RO-B-F, Nr. 0806/2010		
Receptionat		Data

Claudiu Burduja

Digitally signed by
 Claudiu Burduja
 Date: 2020.09.07
 09:10:18 +03'00'

OFICIUL ARHITECTURILOR
 DIN ROMANIA
 8060
 Dona - Andra
 TONCA
 Arhitect cu drept de practica



PROIECTANT	NUME	SEMNATURA	Scara:
SPECIFICAȚIE	TONCA B.		1:100
ȘEF PROIECT	Arh. TONCA D.		Data:
PROIECTAT	Arh. TONCA D.		13.01.2021
DESENAT	Arh. TONCA D.		

Beneficiari:		NITU NICOLAE, NITU MARIANA
Titlu proiect:		TRACHE GRIGORE, TRACHE GABRIELA
RECOMPARTIMENTARE SPATIU COMERCIAL		Proiect nr: P002 / 13.01.2021
Amplasat in: STRADA LEORDENI, Nr. 11 (Cv. 32, P. 807), NC 118700, CF 118700 ORAȘUL POPEȘTI-LEORDENI, Județul Ilfov		Faza: D.E.
Titlu planșă: RELEVEU PARTER		Planșa nr: A 01
PROPUNERE RECOMPARTIMENTARE		